

Double-Ended Shear Beam

FEATURES

- Capacities 20k–125k lbs
- Free of horizontal movement
- Insensitive to side load
- Electroless nickel-plated alloy tool steel
- NTEP Class III L 10000 approval from 20k lbs to 125k lbs
- **Optional**
 - FM approval available

APPLICATIONS

- Truck/rail scales
- Silo/hopper/tank weighing
- Fork-lift scales

DESCRIPTION

The double-ended mounting provides good restraint for possible movement of the tanks and, in many cases, eliminates the need for check rods.

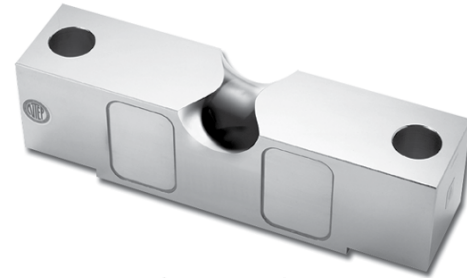

The shear beam design gives excellent performance for high capacity loading.

CLB is constructed of alloy steel and is fully potted with special chemical compounds to IP67 providing excellent protection against moisture and humidity.

OUTLINE DIMENSIONS

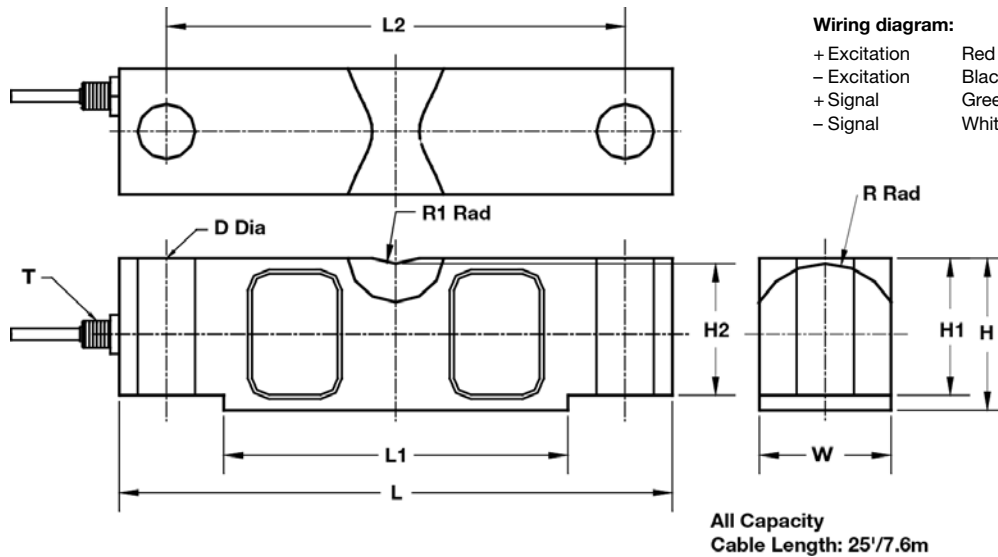

CAPACITY		L	L ₁	L ₂	W	H	H ₁	H ₂	D	R	R ₁	T
20k/25k lbs	mm	196.9	126.7	165.1	42.9	49.3	43.2	41.4	17.3	22.9	19.1	1/4-18NPT
	(inch)	7.75	4.99	6.50	1.69	1.94	1.70	1.63	0.68	0.90	0.75	
40k lbs	mm	260.4	162.3	215.9	49.3	62.0	53.3	50.8	20.6	28.5	25.4	1/4-18NPT
	(inch)	10.25	6.39	8.50	1.94	2.44	2.10	2.00	0.81	1.12	1.00	
50k/60k/75k lbs	mm	260.4	162.3	215.9	62.0	74.7	67.3	64.5	26.9	34.8	25.4	1/2-14NPT
	(inch)	10.25	6.39	8.50	2.44	2.94	2.65	2.54	1.06	1.37	1.00	
100k/125k lbs	mm	387.4	228.4	323.9	73.7	98.0	87.1	83.8	41.2	45.7	38.1	1/2-14NPT
	(inch)	15.25	8.99	12.75	2.90	3.86	2.43	3.30	1.62	1.80	1.50	

Double-Ended Shear Beam

SPECIFICATIONS			
PARAMETER	VALUE		UNIT
NTEP/OIML accuracy class	NTEP III L	Non-Approved	
Maximum no. of intervals (n)	10000 multiple	1000	
$Y = E_{max}/V_{min}$	14000	5000	Maximum available
Standard capacities (E_{max})	20k, 25k, 40k, 50k, 60k, 75k, 100k, 125k		lbs
Rated output—R.O.	3.0		mV/V
Rated output tolerance	0.25		±% of rated output
Zero balance	1		±% of rated output
Non-linearity	0.025		±% of rated output
Hysteresis	0.025		±% of rated output
Non-repeatability	.02		±% of rated output
Creep error (20 minutes)	0.030		±% of rated output
Zero return (20 minutes)	0.030		±% of rated output
Temperature effect on min. dead load output	0.0010	0.0026	±% of rated output/°C
Temperature effect on sensitivity	0.0010	0.0015	±% of applied load/°C
Compensated temperature range	-10 to +40		°C
Operating temperature range	-20 to +60		°C
Safe overload	150		% of R.C.
Ultimate overload	300		% of R.C.
Excitation, recommended	10		VDC or VAC RMS
Excitation, maximum	15		VDC or VAC RMS
Input impedance	770±10		Ω
Output impedance	700±5		Ω
Insulation resistance	>5000		MΩ
Construction	Nickel-plated alloy steel		
Environmental protection	IP67		

All specifications subject to change without notice.

FM Approval

Intrinsically Safe: Class I, II, III; Div. 1 Groups A-G
 Non-Incendive: Class I; Div. 2 Groups A-D